



EICS approved distribution scheme  
test specification

V4

March  
2022

## Contents

1. Introduction .....	6
2. Reference setup for satellite systems.....	6
3. Typical use cases.....	9
Quattro LNB with multiswitch.....	9
Quattro LNB with dSCR .....	10
Wideband LNB.....	10
Signalling .....	10
Functionality.....	11
4. Summary of test cases and requirements .....	12
5. Wanted test signals .....	12
6. Interoperability.....	13
Test 1 – Conformance to signalling standards and platform requirements.....	13
Applicable to DSAT Receivers, Multiswitches, dSCRs:.....	13
Description .....	13
Requirements.....	13
Test method .....	13
Correct command signalling.....	15
Receiver master/slave switching.....	17
7. RF requirements - Satellite.....	17
Test 2 – LNB interference rejection.....	17
Applicable to LNBs:.....	17
Description .....	17
Requirements.....	18
Test method .....	18
Test 3 – Isolation .....	18
Applicable to Multiswitches, Launch amplifiers, dSCRs: .....	18
Description .....	18
Requirements.....	18
Test method .....	18
Trunk to Trunk isolation .....	19
Trunk to receiver isolation .....	20
Test 4 – Output level variation.....	20
Applicable to Multiswitches, Launch amplifiers, dSCRs: .....	20
Description .....	20
Requirements.....	20

Test method .....	21
Test 5 – Input dynamic range.....	23
Applicable to Multiswitches, Launch amplifiers, dSCRs: .....	23
Description .....	23
Requirements.....	23
Test method .....	23
Test 6 – Return loss .....	23
Applicable to Multiswitches, Launch amplifiers, dSCRs: .....	23
Description .....	23
Requirements.....	24
Test method .....	24
Trunk return loss .....	24
Receiver return loss .....	24
8. RF requirements – DTT .....	25
Test 7 – Testing against ETSI EN 303 354.....	25
Applicable to Multiswitches, Launch amplifiers, dSCRs: .....	25
Description .....	25
Requirements.....	25
Test method .....	25
9. Optical testing .....	26
Test 8 – RF to Optical to RF conversion .....	26
Applicable to Optical fibre converters (RF to optical and optical to RF): .....	26
Description .....	26
Requirements.....	26
Test method .....	26

Version history

Version	Date of issue	Comments	Author
V1.0	04/03/2020	Issue 1 of approved distribution test specification	Alex Buchan abuchan@dtg.org.uk
V2.0	30/07/2020	Updates following review <ul style="list-style-type: none"> <li>- New figure added for DiSEqC receiver testing</li> <li>- Isolation – receiver output to receiver output tests</li> </ul>	Alex Buchan abuchan@dtg.org.uk

		<p>removed as agreed on the calls.</p> <ul style="list-style-type: none"> <li>- Isolation – Note added that a spectrum analyser and signal generator could be used for the testing in place of a VNA</li> <li>- Output level variation – Trunk to receiver tests added</li> <li>- Note added to clarify that comparisons of levels are for the same frequency points and not between different parts of the band</li> <li>- DTT Gain Variation – Note added to clarify the requirements for multiswitches</li> <li>- Optical testing added</li> </ul>	
V3.0	28/08/2020	<p>Updates following feedback</p> <ul style="list-style-type: none"> <li>- Section 6, tests 3 and 4 – option was added to test the products with generated satellite signals and a spectrum analyser, instead of a VNA, which could be affected by the AGC of the device</li> <li>- Section 6, test 4 – clarification was added as to how the requirements are assessed</li> <li>- Section 8, test 7 – a note was added that DTT selectivity requirements in EN 303 354 are not applicable to multiswitches as filtering of signals such as LTE is handled at the beginning of a system before reaching multiswitches</li> </ul>	<p>Alex Buchan abuchan@dtg.org.uk</p>
V4.0	01/03/2022	<p>Added link to CAI COP01 for terrestrial and satellite MDU systems</p>	<p>Alex Buchan abuchan@dtg.org.uk</p>

		<p>Added clarification that fibre products covered are both transmitters and gateways</p> <p>Updated title of the document to reference EICS and CAI</p> <p>Removed details of DiSEqC analyser</p> <p>Updated the LNB test to reflect that it is self declaration</p>	
--	--	-----------------------------------------------------------------------------------------------------------------------------------------------------------------------------------------------------------------------------------------------------------------------	--

## 1. Introduction

This document outlines the product characteristics and test process required to meet the DTG and CAI EICS scheme. The aim of the scheme is to verify the efficient use of spectrum and interoperability of DTT and satellite integrated reception system (IRS) distribution equipment such as LNBS, dSCRs, multiswitches, fibre products, and satellite and DTT receivers.

The background for the scheme is that without EICS there are no harmonised standards for these types of equipment to demonstrate compliance to Radio Equipment Directive meaning there is no industry-wide specification to test how spectrally efficient their performance is. Spectral efficiency is a key aspect of a performance and criteria such as isolation, dynamic range, interference rejection, and gain control, all indicate whether a product can perform well in today's environment where multiple technologies are expected to work in adjacent spectrum bands without causing interference to one another.

Similarly, interoperability between receivers and switching equipment is essential to support platform delivery as well as having industry agreed requirements and independent verification of things like signalling and power levels being sent between antennas and receivers.

As such, the EICS product characteristics and associated testing and assurance scheme gives retailers, installers manufacturers and platforms confidence that products will perform as intended and are compatible with platform requirements, providing system integrity.

This document is separated into two main sections: Interoperability (between DSAT receivers and multiswitches or dSCRs) and RF requirements (for LNBS, launch amplifiers, multiswitches, dSCRs, and fibre products such as optical transmitters).

## 2. Reference setup for satellite systems

Below is a typical basic setup for an integrated reception system (IRS) in an MDU. This shows a quattro LNB with an amplifier and multiswitches providing outputs to homes.

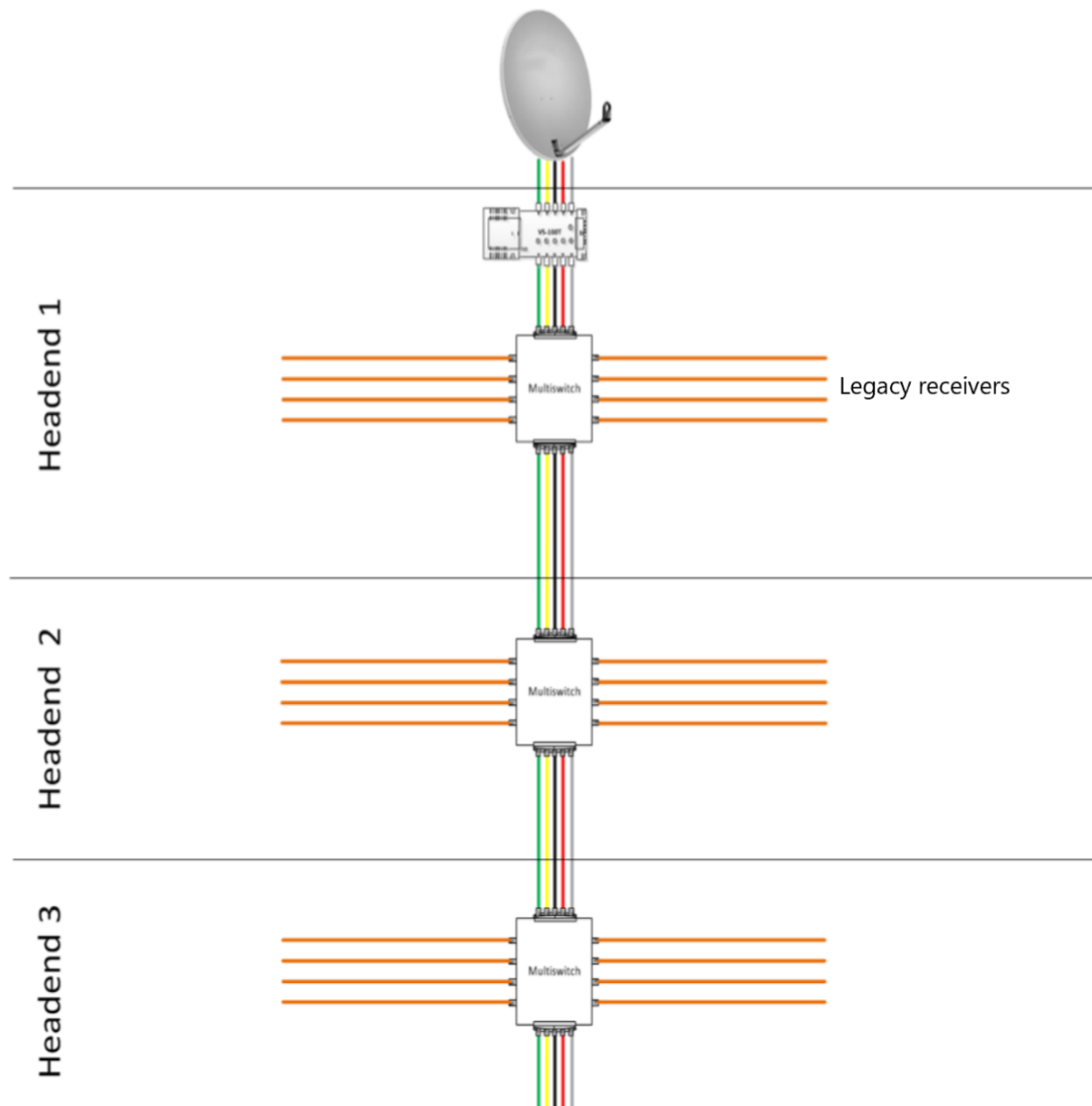

Figure 1 Typical IRS distribution system to legacy satellite receivers

An IRS system would also include DTT, DAB, FM inputs.

Refer to CAI Code of Practice 01 (COP 01) – Installation of Terrestrial & Satellite TV Reception Systems (MDU & Commercial)<sup>1</sup>

The system could also be fed with wideband LNB inputs. In these situations, there would only be two inputs to the switch from the LNB or potentially two separate wideband satellite feeds which would then use the four inputs to the switching equipment. The switches would have to support wideband inputs.

Alternatively, dSCRs could be used to support single cable receivers such as those used by Sky Q. Below is a diagram of how dSCRs could be integrated into existing systems or added on using outputs of the multiswitches. In the latter configuration a ‘plug in’ dSCR is used which is also called a dCSS (digital channel stacking switch).

<sup>1</sup> <https://www.cai.org.uk/index.php/contact/downloads/codes-of-practice-and-regulations/50-cop-01-installation-of-terrestrial-satellite-tv-reception-systems-mdu-commercial>

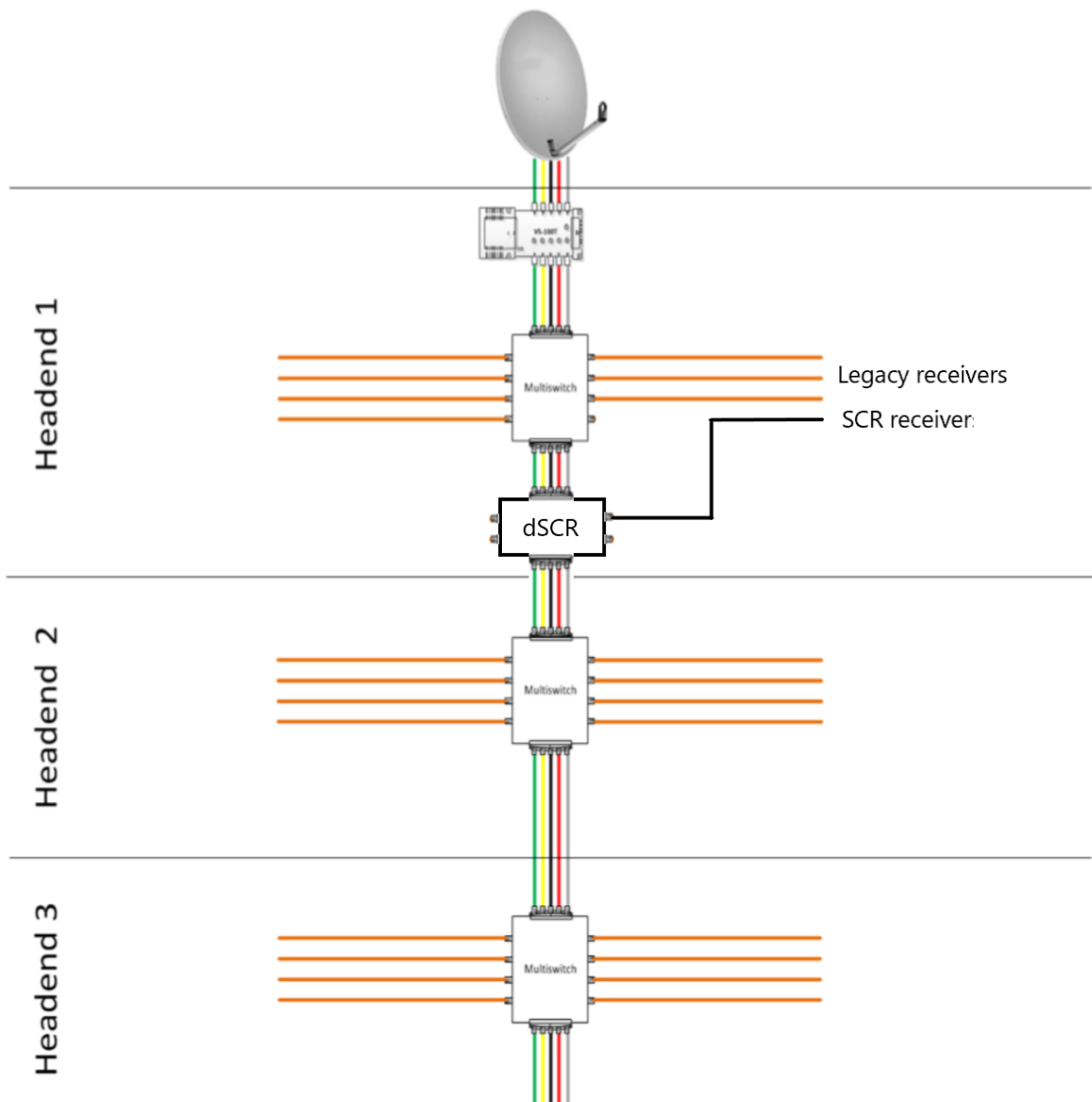

Figure 2 Typical IRS distribution system to legacy and SCR satellite receivers



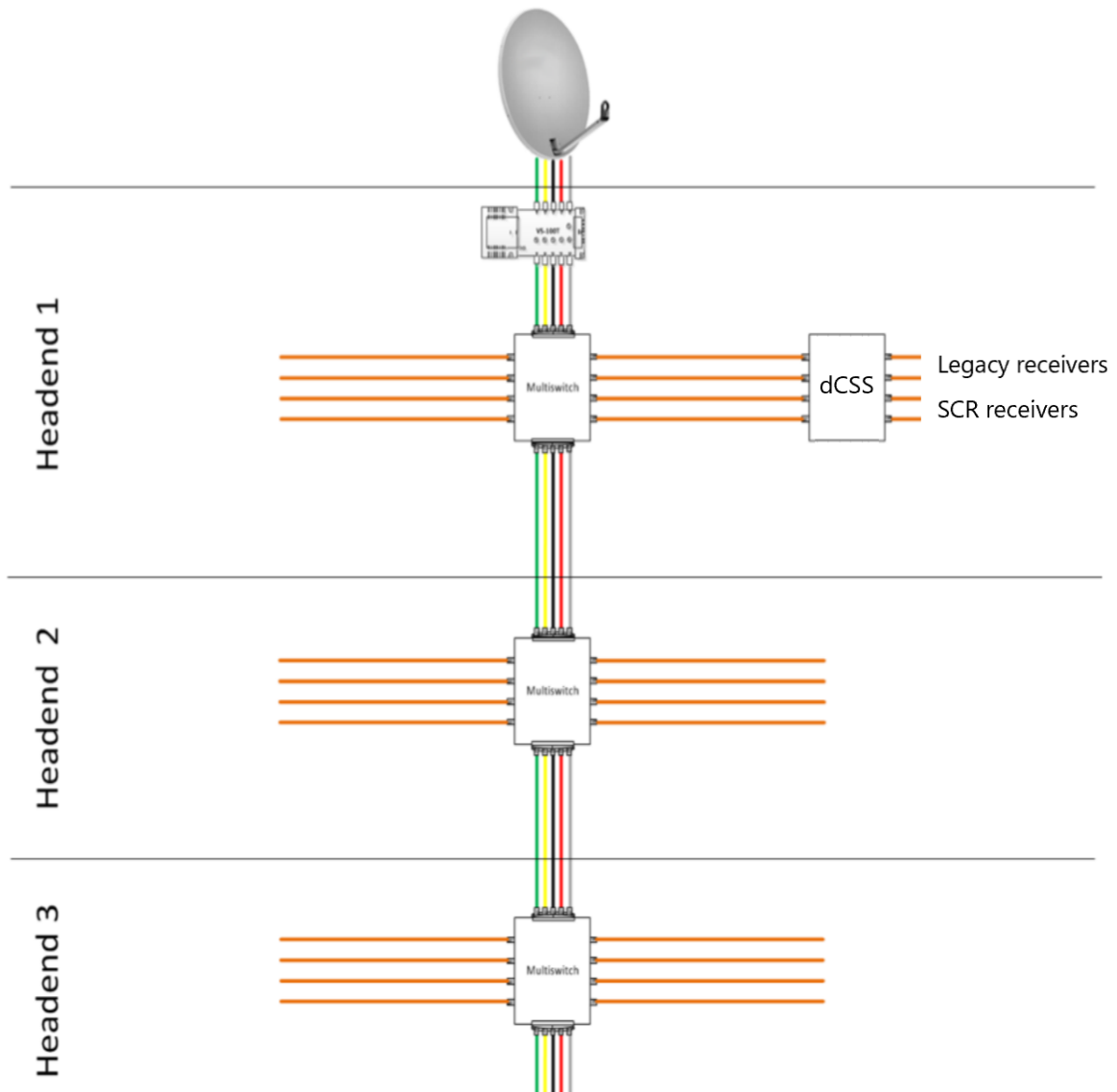

Figure 3 Typical IRS distribution system to legacy and SCR satellite receivers using a 'plug in' dCSR/dCSS

The configurations above could be applied at a reduced level to a single occupancy building as well.

### 3. Typical use cases

#### Quattro LNB with multiswitch

In most situations where there are multiple dwellings, a quattro LNB is used at the input to the system which provides four satellite quadrants with TV services shared amongst each:

- 1) Vertical high
- 2) Vertical low
- 3) Horizontal high
- 4) Horizontal low

The services are received at RF frequencies ranging from 10.7 GHz to 12.7 GHz, which are then down converted to an intermediate frequency (IF) at the output of the LNB which ranges from 950 MHz to 2150 MHz.

As shown in the reference diagrams above, these are then amplified and fed to multiswitches which make each of the inputs available at multiple outputs, where each output serves an individual tuner.

From the tuner's perspective, signalling commands are used to instruct the multiswitch which TV service the viewer wants. The multiswitch then selects the service from one of the four input quadrants and places it on the output port so the tuner can receive it.

The issue with this setup generally is that each tuner must have a separate output port of the multiswitch. Otherwise, if there were multiple tuners on the same output port and they were requesting different services, the switch would not be able to distinguish which service to select. As a result, if a view had a receiver with four tuners integrated, e.g. for viewing and multiple recordings, then the receiver would need four cables from four outputs of the multiswitch to allow this to work.

### Quattro LNB with dSCR

To get around the problem described above, a dSCR can be used. SCR stands for single cable router, which as the name suggests allows everything to operate on a single cable.

This is made possible by the dSCR which, like multiswitches, takes the requests for TV services from the tuners and then selects the correct service from the four quadrant inputs and places it on the output port. The difference with a dSCR and a multiswitch is that the dSCR makes use of user bands on the output ports which are essentially blocks of frequencies that are allocated on the cable to allow multiple TV services to be sent down a single cable. That way the receiver can have multiple tuners in operation with just a single cable from the dSCR.

In reality some installations connect multiple receivers to a single output port which can cause issues with the interoperability between the receivers and the switches due to signalling clashes.

The dSCR operation allows receivers to have many tuners integrated into the design as now they can all be fed from a single RF connection.

### Wideband LNB

A wideband LNB differs from a quattro LNB by providing two outputs instead of four. These cover the horizontal and vertical polarisations as in the case of the quattro but the wideband LNBs do not further divide the signal into low and high bands.

This is done by having a wider IF range to provide more bandwidth to distribute the services.

The wideband IF range is from 290 MHz to 2340 MHz in contrast to the Quattro IF range which is from 950 MHz to 2150 MHz.

Wideband LNBs can be used in both multi-dwelling as well as single occupancy buildings where in the former it would be used with wideband capable switches, and the latter would provide two cables to the receiver to cover the horizontal and vertical polarisations.

### Signalling

For the above systems to work, a range of signalling is required between the receivers and the distribution equipment to combine everything into something that is seamless to the end user.

Additionally, the user does not want to have slow channel changes meaning the signalling commands need to be short, easy to decode, and implement.

The first signalling designed for this use is based on tones and voltages between the receivers and switches to select the TV services from quadrants of the satellite feed.

The tone and voltage signalling works by the receiver providing current at either 13 volts for vertical polarisation or 18 volts for horizontal polarisation. A 22 kHz tone is then used to distinguish between high band (with tone) and low band (without tone).

For single cable router systems, a specification was produced based on the DiSEqC (Digital Satellite Equipment Control) which is called EN 50494. This allows up to 8 satellite feeds e.g. 2x4 quattro inputs and provides up to 8 outputs on a single cable which are called user bands i.e. potentially 8 different tuners sharing the same cable.

The standard was then upgraded to EN 50607 or Single Cable Distribution 2, where the number of inputs to the system increased to 256 (banks, feeds, polarisations) and provides up to 32 outputs/user bands on a single cable.

Below is a diagram of this setup to describe it in more detail which is taken from the EN 50607 standard.

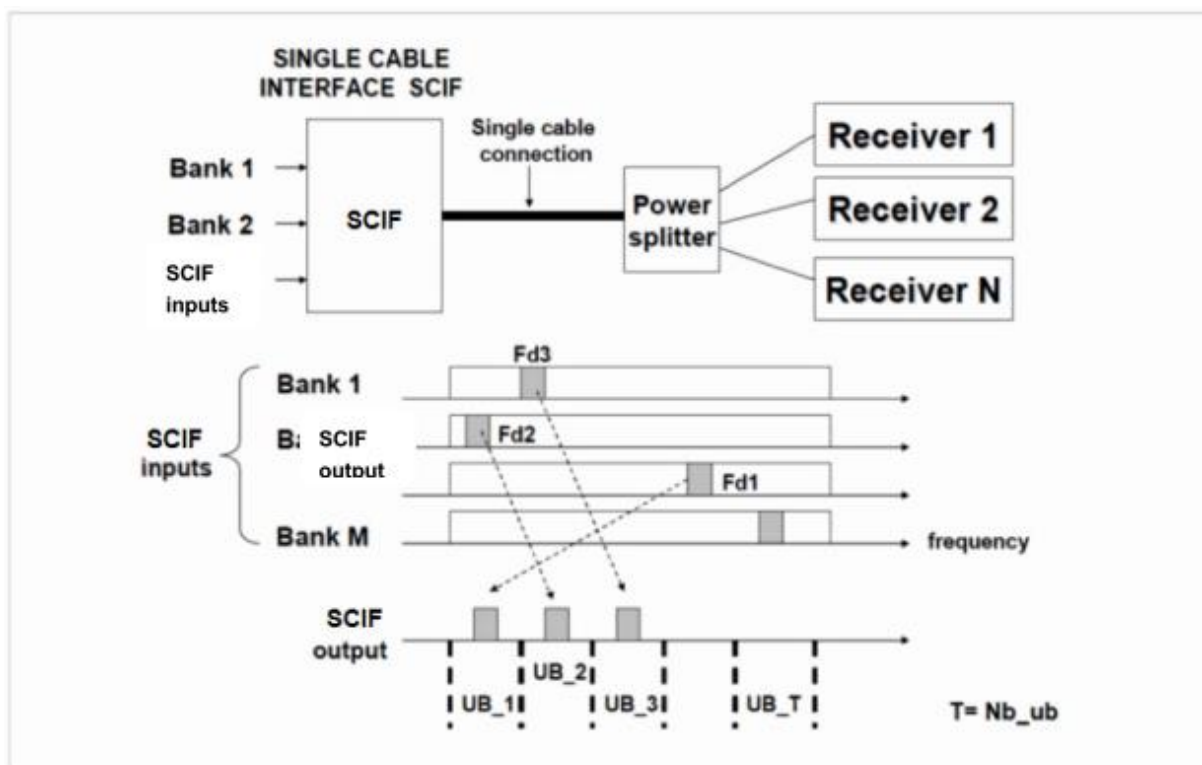

Figure 4 Single cable router concept taken from EN 50607: Single Cable Distribution 2<sup>nd</sup> Edition

### Functionality

The aim of the above configurations is ultimately to provide an improved quality of experience for the viewer.

With the introduction of single cable designs, receivers can now support many more tuners than was possible in legacy tone and voltage systems meaning viewers can watch content on multiple devices, in multiple rooms, while recording multiple shows simultaneously.

This is all possible with a single input cable from the distribution system meaning that setups are simplified.

Additionally, due to the design of the signalling protocols, the system can still manage all this functionality while providing fast channel changes.

## 4. Summary of test cases and requirements

Below is a list of the tests included in this specification along with the targets for conformance.

Test Number	Title	Applicable to	Targets
1	Signalling standards and platform requirements	R, M, F, d	Signalling waveform, voltage levels, timings conformance to EN 50607, DiSEqC, Sky Q
2	LNB interference rejection	LNB	≥30dB of interference rejection, and conformance to ETSI EN 303 372-1 <b>NOTE THIS TEST IS SELF-DECLARATION</b>
3	Isolation trunk to trunk and receiver to receiver	M, L, d	≥30dB trunk to trunk and ≥26dB trunk to receiver isolation
4	Output level variation	M, L, d	±2dB signal level variation compared to the typical values in the manufacturer specification when tested against the highest and lowest input values across all output ports
5	Input dynamic range	M, L, d	No more than 2dB MER level variation between the highest and lowest input signal levels
6	Return loss	M, L, d	≥10dB for trunk input and output, ≥6dB for receiver output ports
7	RF requirements - DTT	L	As per ETSI EN 303 354
7	RF requirements - DTT	M, d	As per ETSI EN 303 354 except for Selectivity and NF which is N/A and for gain variation which is ±2dB level variation compared to the typical values in the manufacturer specification
8	RF to Optical to RF conversion	F	No more than 4dB MER level degradation after conversion from RF to optical and back to RF. This is over the frequency band of operation and from a starting level of 15dB MER <b>NOTE THIS TEST IS SELF-DECLARATION</b>

Where:

- R = receiver
- M = multiswitch
- L = launch amplifier
- F = Fibre product covering both optical to RF gateway and RF to optical transmitter
- d = dSCR
- LNB = Low Noise Block downconverter

## 5. Wanted test signals

For any tests requiring a simulated satellite test signal, the following parameters will apply:

The wanted waveforms for the testing are:

Legacy: DVB-S2 27500 2/3 8PSK

For tests at one frequency, this will be 1550MHz for legacy, which is the centre frequency between 950 and 2150MHz for legacy equipment and:

Wideband: DVB-S2 27500 2/3 8PSK

For tests at one frequency, this will be 1315MHz for wideband, which is the centre frequency of the wideband frequency range.

## 6. Interoperability

### Test 1 – Conformance to signalling standards and platform requirements

Applicable to DSAT Receivers, Multiswitches, dSCRs:

#### Description

EN 50607 is the standard for satellite distribution over a single cable router. It is the second-generation of the standard and follows on from EN 50494 which was the first generation. Equipment that is compliant with EN 50607 is backward compatible with EN 50494.

The second-generation standard introduces enhancements to the number of inputs and outputs that devices can support with 32 output user bands compared to 8 for first generation devices and 256 IF banks at the input compared to 8 for first generation devices.

In addition to EN 50607, Sky Q devices have their own proprietary requirements and DiSEqC is a widely used standard.

Although the standards are a guideline for building a device, the aim of this test regime is to verify correct operation by checking aspects such as the message structures, and, communication between receivers and distribution equipment.

#### Requirements

Messages are sent with correct tone voltage within the tolerances as required in DiSEqC, SCR 50494, 50607, Sky

Messages are sent with the correct frequency as required in DiSEqC, SCR 50494, 50607, Sky

Messages are sent with the correct waveform as required in DiSEqC, SCR 50494, 50607, Sky

Receivers can switch between slave and master impedance

#### Test method

The device under test (DUT) will be connected to a form simple network of receiver and distribution equipment e.g. if the DUT is a switch it will be connected to a receiver and vice versa.

The reason for this is to allow communication from the DUT.

A DiSEqC analyser will be used to verify communication between receivers and distribution equipment. This will be connected in line between the DUT and the receiver/switch as shown below:

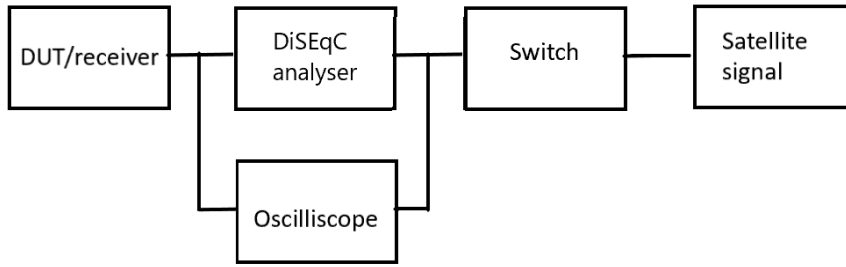

Figure 5 test setup for receiver interoperability testing (Sky Q and SCR)

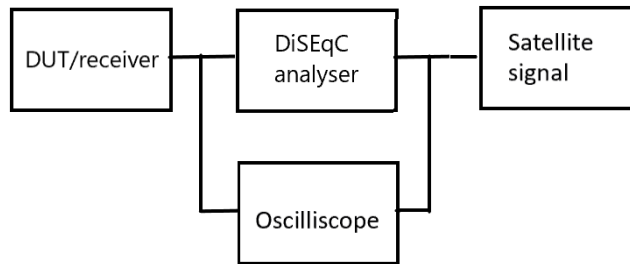

Figure 6 test setup for receiver interoperability testing (DiSEqC receiver)

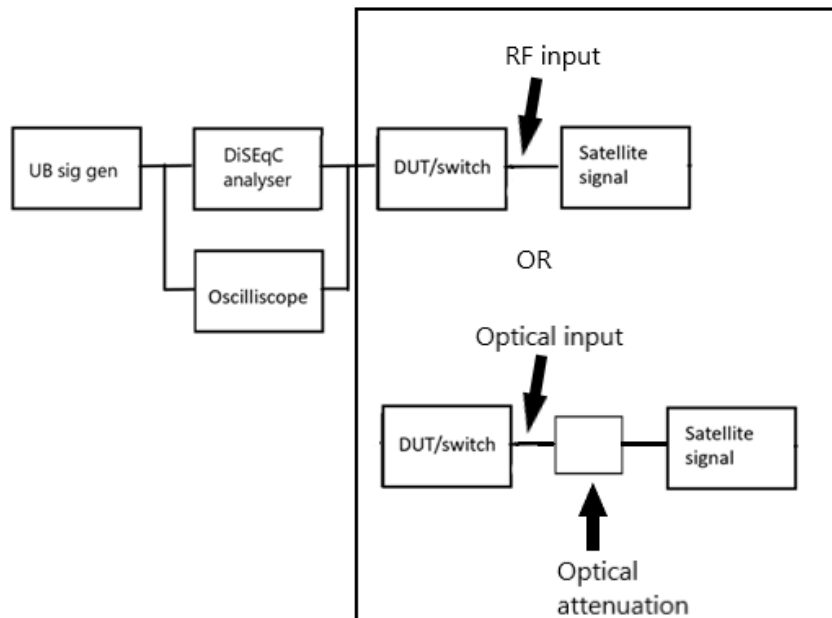

Figure 7 test setup for switch interoperability testing

Where the UB signal generator is equipment that can generate the correct waveform to request a satellite userband (UB). This is to simulate a receiver request a service but means that specific UBs

can be requested to ensure a controlled test can be carried out. A Promax HD Ranger or Inverto SatPal is capable of this functionality.

The Sat signal generator for the switch testing is where a signal generator is used to provide the wanted test signal. The parameters for the wanted test signal are in the next section.

In addition to the message information, an oscilloscope will also be used to verify the levels and timings of the waveforms for compliance.

#### Correct command signalling

Once the equipment is set up as shown above, the following tests apply.

During the tests the analyser will be used to verify that the correct signal is sent.

The oscilloscope will be used to verify that the waveform is in the correct format as specified in the standards (DiSEqC, BS EN 50494, BS EN 50607, Sky Q).

#### Sky Q compliance receiver testing

Set up as per Figure 5 test setup for receiver interoperability testing

The following is required to be will be initiated by changing channel on a Sky Q receiver:

SCR\_channel\_change

The details of the channel change command are below for the purpose of verifying the results:

Byte	Bit	Field	Description
1	7:0	Framing (8 bits)	DiSEqC framing sequence 0xC1
2	7:3	UB (5 bits)	SCR band that is the target of this command
2	2	Polar (1 bit)	0b0: vertical polarisation 0b1: horizontal polarisation
2	1:0	CFD (10 bits)	Channel Frequency Descriptor = $(Fch - 10700)/2$
3	7:0		

Where

The channel frequency descriptor (CFD) sent must be correct as specified in the Sky Q requirements which is C1h and can be verified using the DiSEqC analyser.

The polarisation request sent must be correct as specified in the Sky Q requirements and can be verified using the DiSEqC analyser

The Channel Frequency Descriptor (CFD) must be correct as specified in the Sky Q requirements and can be verified using the DiSEqC analyser

Using the oscilloscope verify the following regarding the waveform:

Voltage =  $11.6V \pm 1V$

Carrier frequency =  $22 \text{ kHz} \pm 20\%$

Carrier amplitude =  $650\text{mV peak-peak} \pm 250\text{mV}$

Modulation mark period =  $500 \mu\text{s} \pm 100 \mu\text{s}$

Modulation space period =  $1 \text{ ms} \pm 200 \mu\text{s}$

#### *Sky Q compliance switch testing*

Set up as per Figure 7 test setup for switch interoperability testing

Set up the satellite signal generator using the legacy mode settings as described in section 4.

Using the UB Signal generator, configure the setup so that the wanted signal is modulated onto UB14 1480 MHz.

Using the UB signal generator, request UB14 1480 MHz from the switch.

The result is that the UB signal generator shall display the test signal and the content is sent via UB14.

#### *SCR compliance receiver testing:*

Set up as per Figure 5 test setup for receiver interoperability testing

Initiate the following commands using the receiver under test:

ODU\_Channel\_change – Unidirectional command sent by the receiver for tuning to a required channel. Initiate the command from the receiver and verify using the DiSEqC analyser the bytes sent by the receiver are correct as per section 7.1 of BS EN 50607.

Initiate the channel change command again and using the oscilloscope verify the following regarding the waveform:

Low DC Voltage = 12.5V to 14V

High DC Voltage = 17V to 19V

Carrier frequency =  $22 \text{ kHz} \pm 20\%$

Carrier amplitude = 650mV peak-peak  $\pm 250\text{mV}$

Modulation mark period =  $500 \mu\text{s} \pm 100 \mu\text{s}$

Modulation space period –  $1 \text{ ms} \pm 200 \mu\text{s}$

#### *SCR compliance switch testing*

Set up as per Figure 7 test setup for switch interoperability testing

Set up the satellite signal generator using either the legacy mode or wideband settings as described in section 4.

Using the UB Signal generator, configure the setup so that the wanted signal is modulated onto UB9 1585 MHz.

Using the UB signal generator, request UB9 1585 MHz from the switch.

The result is that the UB signal generator shall display the test signal and the content is sent via UB9.

#### *DiSEqC compliance receiver testing*

Set up as per Figure 6 test setup for receiver interoperability testing (DiSEqC receiver)

Initiate the following commands using the receiver under test:

Set Lo – Select the low local oscillator frequency



Set VR – Select vertical polarisation

Set Hi – Select the high local oscillator frequency

Set HL – Select the horizontal polarisation

Using the DiSEqC analyser, verify in each case that the correct voltage and band information is sent by the receiver under test as per below:

12.5V – 14V for vertical polarisation

17V – 19V for horizontal polarisation

22kHz tone for high band

No tone for low band

Initiate the Set HL command again and using the oscilloscope verify the following regarding the waveform:

Carrier frequency = 22 kHz  $\pm$  20%

Carrier amplitude = 650mV peak-peak  $\pm$  250mV

Modulation mark period = 500  $\mu$ s  $\pm$  100  $\mu$ s

Modulation space period – 1 ms  $\pm$  200  $\mu$ s

ToneBurst duration = nominally 12.5 ms

#### *DiSEqC compliance switch testing*

Set up as per Figure 7 test setup for switch interoperability testing

Set up the satellite signal generator using either the legacy mode as described in section 4.

Using the UB Signal generator, configure the setup so that the wanted signal is modulated onto each of the four quadrants in turn: VL, VH, HL, HH and request the test signal from the switch.

The result is that the UB signal generator shall display the test signal and the content is sent on the band configured.

#### *Receiver master/slave switching*

When back-channel signalling is to be supported (DiSEqC Implementation Level 2.0 and above), the Master transmitter (in the Tuner-receiver/IRD) should present a nominal source impedance of 15ohm to the bus, at 22 kHz.

The receiver manufacturer shall declare that the product meets the above requirement

## 7. RF requirements - Satellite

### Test 2 – LNB interference rejection

Applicable to LNBs:

#### Description

The LNB is the input to the IRS system so this test is to check that interfering signals present at the LNB are reduced as far as possible by the time they reach the LNB output. Examples of interfering

signals that could be present are intermodulation products from 5G systems operating at 26 GHz mixing with satellite signals at 12 GHz and causing a signal at  $f_2-f_1$  of 14 GHz.

### Requirements

LNBS must demonstrate compliance to ETSI EN 303 372-1 Harmonised Standard Covering the Essential Requirements of Article 3.2 of Directive 2014/53/EU (Radio Equipment Directive)

### Test method

This test is self-declaration

## Test 3 – Isolation

Applicable to Multiswitches, Launch amplifiers, dSCRs:

### Description

This test measures the isolation of signals from each of the DUT inputs e.g. isolation of input 1 to input 2, isolation of input 1 to input 3 and so on. Typically, these inputs would be 4 satellite quadrants and DTT but the test is independent of the signal type. The test is aimed at verifying that signals of different types do not get mixed at the DUT input causing potential poor-quality output signals.

Tests will be repeated for

- trunk in to trunk out
- trunk in to receiver out

### Requirements

30dB trunk to trunk isolation and receiver to receiver isolation.

26dB trunk in to receiver isolation.

### Test method

The frequency range for the testing will be satellite IF 950 MHz to 2150 MHz for legacy and 290 MHz to 2340 MHz for switches with wideband inputs. NOTE if a VNA cannot be used then a signal generator and spectrum analyser could be used instead to make measurements at the top, middle and bottom of the IF band as shown in the figure.

The setup will be as per below. This shows the setup for trunk in to trunk out..

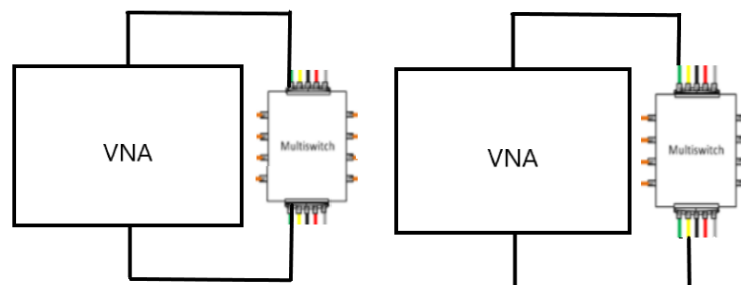

Figure 8 setup for trunk to trunk isolation step 1 (left) and step 2 (right)

For trunk to receiver the VNA or signal generator and spectrum analyser will be connected to ports as shown below

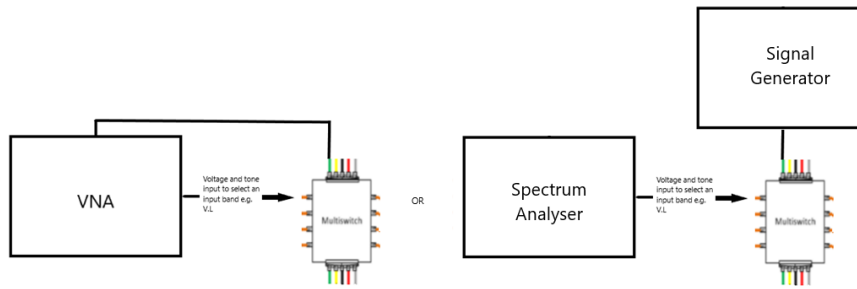

Figure 9 setup for trunk to receiver isolation Step 1

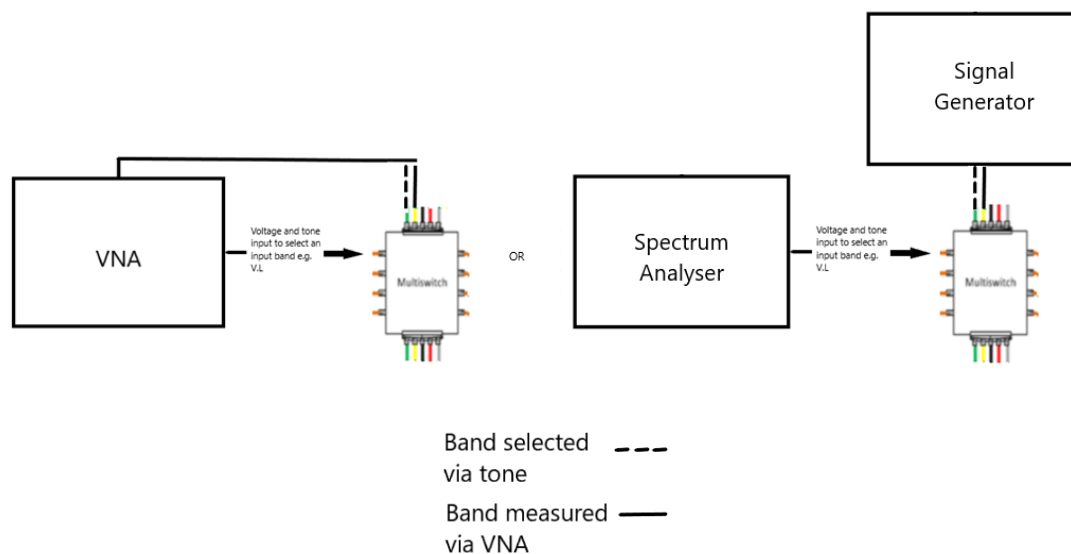

Figure 10 setup for trunk to receiver isolation Step 2

Ensure the VNA is calibrated so that cable losses are accounted for and the initial reading without the DUT connected is at 0dB across the entire frequency range.

Also ensure that impedance matching from 50 ohm to 75 ohm is included between the VNA and the DUT if required.

Put 75 ohm terminations on all other input and output ports that are not being measured.

Use a VNA to make an S21 measurement sweep across the IF input range of the device under test

For the signal generator method, a satellite carrier will be configured as per Section 5 – Wanted Test Signals, with the frequency set to the middle of the range for the port being tested e.g. VL. Set the input level of the carrier to the centre range of the signal input levels included in the manufacturer declarations. Measure the output on the spectrum analyser.

#### Trunk to Trunk isolation

Port 1 of the VNA will be connected to one of the input ports on the DUT e.g. VL.

Port 2 of the VNA will be connected to the corresponding output port of the DUT e.g. VL in to VL out.

A measurement with the VNA is taken and recorded.

Port 2 of the VNA will then be connected to the adjacent output port of the DUT e.g. VL in to VH out.

A measurement with the VNA is taken and recorded.

The result for the second measurement must be 30dB lower across the frequency band than the first measurement.

Repeat for all satellite inputs (x4 for legacy and x2 for wideband) and for each measure the immediately adjacent output ports.

Also repeat for the DTT input port from 470 MHz to 2150 MHz for legacy products and from 290 MHz to 2350 MHz for wideband products and measure the output on the two adjacent output ports to the DTT trunk.

#### Trunk to receiver isolation

A DC voltage is applied at the first output port to select an input port e.g. VL.

Port 1 of the VNA will be connected to the input port on the DUT that is being selected according to the voltage being applied e.g. VL.

Port 2 of the VNA will be connected to the first output port of the DUT.

A measurement with the VNA is taken and recorded.

With the DC voltage still being applied to the first output port of the DUT, Port 1 of the VNA will then be connected to the adjacent input port of the DUT to the one being selected as shown in the figure above e.g. if VL is being requested, connect Port 1 of the VNA to VH.

A measurement with the VNA is taken and recorded.

The result for the second measurement must be 26dB lower across the frequency band than the first measurement.

Repeat for all satellite inputs of the DUT.

## Test 4 – Output level variation

Applicable to Multiswitches, Launch amplifiers, dSCRs:

### Description

The signal level at the output of the DUT may vary because of splitting the input signals and distributing them down different paths within the device. This test ensures that the variation in levels at the outputs of the DUT do not vary by such an amount so that the performance from port to port is inconsistent. The test will compare the output value to the typical output value declared in the manufacturer specification for a given input level. The ports tested all must be within a set range, given below, of the typical output value.

### Requirements

The result shall nominally be  $\pm 2$ dB level variation from the typical value for output level stated in the manufacturer specification. If this is not possible then a justification with technical evidence must be provided to explain the reason for additional allowance.

NOTE The input level for the test will be set to the middle of the input level specified in the manufacturer declaration for a given output level. Also note that output level will vary depending on

the number of carriers at the input so this needs to be factored into the expected output level based on the manufacturer declaration. In general doubling the input carriers reduces the output level of each carrier by 3dB compared to the manufacturer declaration.

### Test method

Carry out a signal sweep across the device input frequency range for each input. Ensure the variation is within the requirement. NOTE if a VNA cannot be used then a signal generator and spectrum analyser could be used instead to make measurements at the top, middle and bottom of the IF band as shown in the figure.

The test will be done with a VNA as shown in the diagram below.

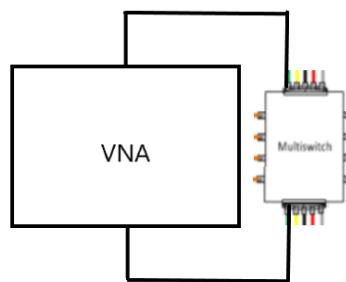

Figure 11 setup for output level variation testing trunk to trunk

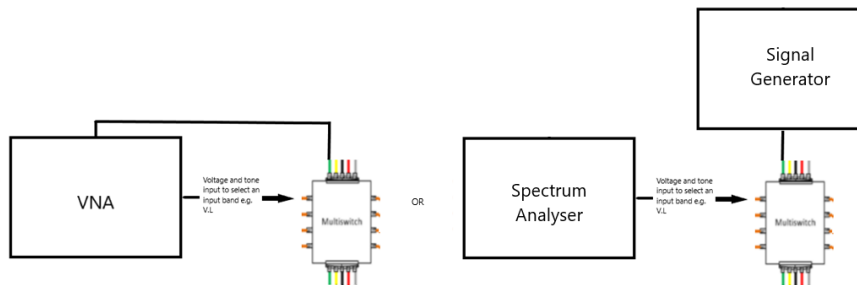

Figure 12 setup for output level variation testing trunk to receiver Step 1

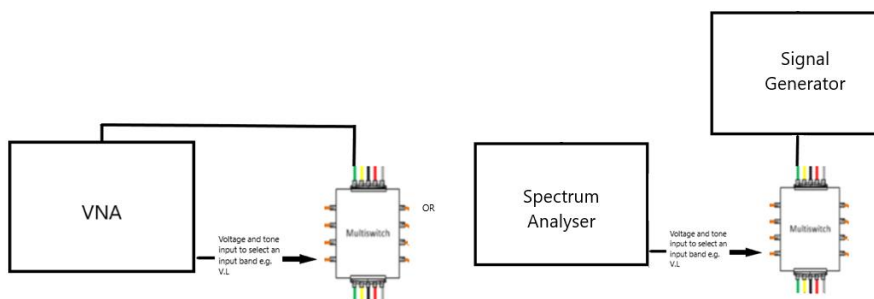

Figure 13 setup for output level variation testing trunk to receiver Step 2

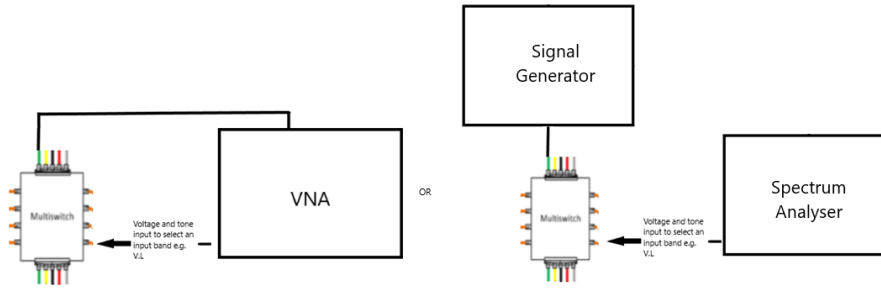

Figure 14 setup for output level variation testing trunk to receiver Step 3

Ensure the VNA is calibrated so that cable losses are accounted for and the initial reading without the DUT connected is at 0dB across the entire frequency range.

Also ensure that impedance matching from 50 ohm to 75 ohm is included between the VNA and the DUT if required.

Put 75 ohm terminations on all other input and output ports that are not being measured.

Ensure that the slope settings are set to minimum on the DUT.

Use a VNA to make an S21 measurement sweep across the IF input range of the device under test

The return path of the VNA will be connected to the through port of the switch opposite where the input path of the VNA is connected.

For the signal generator method, an satellite carrier will be configured as per Section 5 – Wanted Test Signals, with the frequency set to the middle of the range for the port being tested e.g. VL. Set the input level of the carrier to the centre range of the signal input levels included in the manufacturer declarations. Measure the output on the spectrum analyser.

The input frequency range for the VNA will be 950 MHz to 2150 MHz for legacy and dSCR inputs and 290 MHz to 2340 MHz for switches with wideband inputs.

Repeat for all satellite inputs (x4 for legacy and x2 for wideband). Note the DTT input is tested in section 8 of this specification.

Repeat the test for one satellite input but connecting the output of the VNA or spectrum analyser to a receiver port as shown in Figure 12 setup for output level variation testing trunk to receiver Step 1

Repeat the test for one satellite input but connecting the output of the VNA or spectrum analyser to receiver port as shown in Figure 13 setup for output level variation testing trunk to receiver Step 2

Repeat the test for one satellite input but connecting the output of the VNA or spectrum analyser to receiver port as shown in Figure 14 setup for output level variation testing trunk to receiver Step 3

The result for each port must be within the range specified in the requirements section above compared to the typical output value declared by the manufacturer.

## Test 5 – Input dynamic range

Applicable to Multiswitches, Launch amplifiers, dSCRs:

### Description

Due to the automatic gain control used in satellite switches, input dynamic range testing will be used to test the strong signal handling of the DUT in place of intermodulation testing. The test will also verify correct operation of the AGC functionality by making measurements on the output signals over a range of input signal levels.

### Requirements

Measurements will be done over the ranges required by platforms and recommended requirements for wall sockets – considering cable losses

MER degradation at each output port of the device shall be less than 2dB across the range of input power levels declared by the manufacturer.

This is compared to a starting MER of 15dB.

### Test method

The setup will be as per the diagram below.

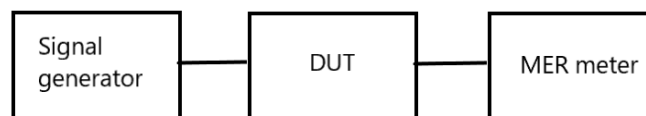

*Figure 15 setup for input dynamic range testing*

At each satellite input port of the device, input a signal at the lowest value of the stated input voltage ranges.

At the output measure the MER of the test signal.

Repeat the measurement for the upper input signal level from the manufacturer's stated range of operation.

The result is a pass if the MER and output signal level is within the requirement limits between all ports and input signal levels.

The input signal will be a representative DVB-S and DVB-S2 signal see section 4 for the description of the test signal.

The test will be carried out for the bottom, middle and top of the satellite frequency ranges.

The frequency range will be 950 MHz to 2150 MHz for legacy inputs and 290 MHz to 2340 MHz for switches with wideband inputs.

## Test 6 – Return loss

Applicable to Multiswitches, Launch amplifiers, dSCRs:

### Description

Return loss is another key aspect to signal quality, a poor return loss will result in reflection from terminations that are badly matched, creating standing waves which could distort wanted signals.

Tests will be repeated for

- trunk in and trunk out
- Receiver out

### Requirements

Minimum input and output return loss is 10dB for the lower, middle, and upper frequency range of the device under test for each trunk port.

Minimum input and output return loss is 6dB for the lower, middle, and upper frequency range of the device under test for the top and bottom output port on each rail of the DUT.

### Test method

The test shall be carried out using a vector network analyser (VNA) or suitable tracking generator with a 75ohm impedance or 75ohm impedance setting.

The setup using a network analyser is shown below.

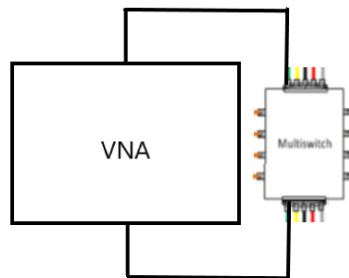

Figure 16 trunk return loss measurement

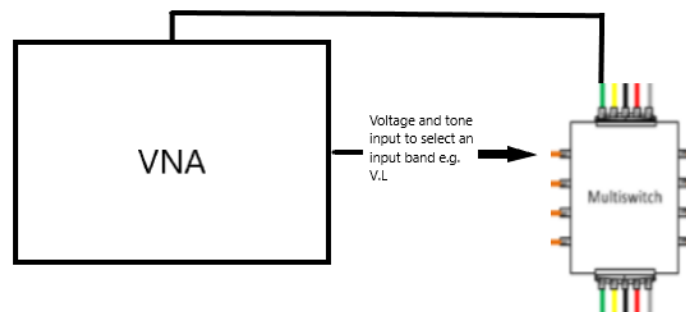

Figure 17 output port return loss measurement

### Trunk return loss

The VNA will be connected to the input of the port under test with the output terminated with a 75 ohm impedance.

The measurements will be repeated for the top, middle, and bottom of the IF frequency range of 950 MHz to 2150 MHz for legacy and 290 MHz to 2340 MHz for switches with wideband inputs.

Once completed for **one** of the satellite inputs, the test should be repeated for the corresponding trunk output port by switching round the VNA connections.

### Receiver return loss

For the receiver port the VNA is connected to the input port a DC voltage is applied at the first output port to select a input port e.g. V.L



Port 1 of the VNA will be connected to the input port on the DUT that is being selected according to the voltage being applied.

Port 2 of the VNA will be connected to the first output port of the DUT.

A measurement with the VNA is taken and recorded. The measurements will be repeated for the top, middle, and bottom of the IF frequency range of 950 MHz to 2150 MHz for legacy and 290 MHz to 2340 MHz for switches with wideband inputs.

The test shall be repeated for the top and bottom output port for each rail of the DUT i.e. 4 tests in total.

The DTT port is tested in section 8 of this specification.

## 8. RF requirements – DTT

### Test 7 – Testing against ETSI EN 303 354

Applicable to Multiswitches, Launch amplifiers, dSCRs:

#### Description

DTT inputs of multiswitches and dSCRs will be tested against the requirements for DTT amplifiers specified in the ETSI standard EN 303 354. This covers requirements for the following:

- Section 4.5.1 Gain variation
- Section 4.5.2 Noise figure
- Section 4.5.3 Amplifier intermodulation
- Section 4.5.4 Return loss (input and output)
- Section 4.5.5 Selectivity (if applicable)
- Section 4.5.9 Internal immunity

#### Requirements

As described in EN 303 354 for Launch amplifiers.

For Multiswitches:

- Noise figure is not applicable
- Gain variation targets will be verified according to the manufacturer specification – the results shall nominally be within  $\pm 2$ dB of typical values declared by the manufacturer and across the frequency range specified by the manufacturer. For example, if the manufacturer states that gain variation is  $\pm 2$ dB across the band then the requirements for the spec will be  $\pm 4$ dB
- Selectivity is not applicable as filtering is done at a system level before reaching the multiswitches
- All other tests in EN 303 354 are applicable

#### Test method

As described in EN 303 354 latest version.

## 9. Optical testing

### Test 8 – RF to Optical to RF conversion

Applicable to Optical fibre converters (RF to optical and optical to RF):

#### Description

This test is self-declaration. Conformance is demonstrated by the manufacturer supplying test reports to DTG to demonstrate the requirements below have been met.

The purpose is to test the performance of an optical system & individual key active elements (transmitter at the head end) that convert RF to optical for onwards distribution & then convert the signals back to RF (optical to RF receiver/Gateway Termination Unit GTU) within the home or at the node. The test requires two products from the same manufacturer to simulate an end to end solution of optical distribution with the first unit converting from RF to optical then the second unit converting back from optical to RF.

#### Requirements

Minimum input MER shall be 15dB with a maximum MER degradation of 4dB during conversion of RF signals to fibre and then back to RF.

This shall be demonstrated across the frequency band of operation according to the manufacturer specification.

#### Test method

As this test is self-declaration the setup will be according to the manufacturer facilities, however below is a basic block diagram showing the overall principle of the test.

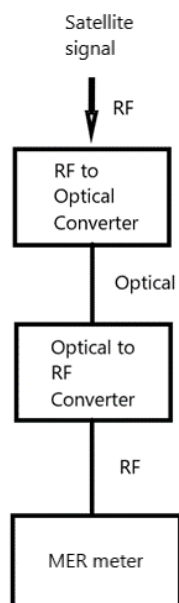

Figure 18 setup for optical testing

Test signals are input into the test system and the MER recorded prior to optical conversion. The system should be sufficiently loaded so as to adequately test the devices and to cover the frequency range of operation.

Once converted to optical, the signal is converted back to RF and the resultant MER degradation recorded on the same frequency that the initial test was carried out pre-conversion.

The measurements are repeated so as to demonstrate conformance over the frequency band of operation for the devices under test.